

# Control Valve

Model BZL

Model BZT

Model BZX

Model JZG



Directly mounted to clamps, flow control valve • Air bleeding • plug

- Directly mounted to clamps



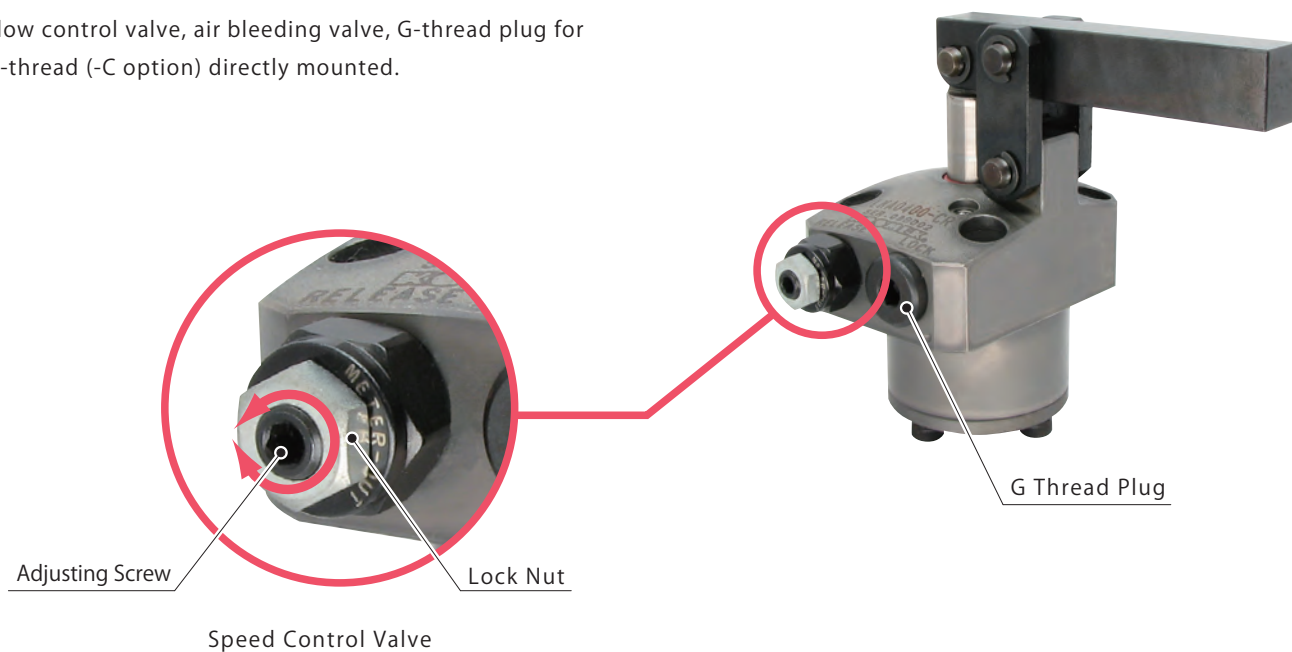

Flow control valve, air bleeding valve, G-thread plug for G-thread (-C option) directly mounted.

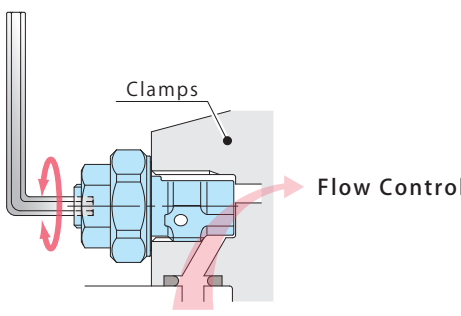
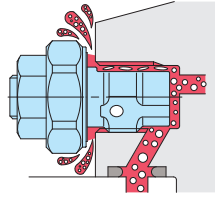

Speed Control Valve  
Model BZL  
Model BZT

Air Bleed Valve  
Model BZX

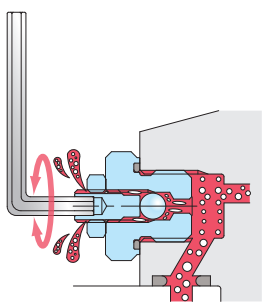
G Thread Plug  
Model JZG

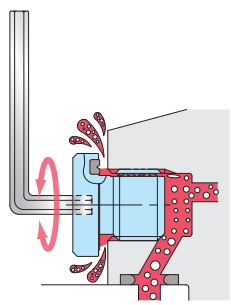
	Operating Pressure Range	Action Description
<p>Speed Control Valve (For Low Pressure)</p> <p>Model <b>BZL</b> → P.729</p> 	7MPa or less	<p>Adjust the flow by wrench. It can adjust the clamping action speed individually.</p> 
<p>Speed Control Valve (For High Pressure)</p> <p>Model <b>BZT</b> → P.733</p>	35MPa or less	<p>Air bleeding in the circuit is possible by loosening flow control valve.</p> 
<p>Air Bleed Valve</p> <p>Model <b>BZX</b> → P.735</p> 	25MPa or less	<p>Air bleeding in the circuit is possible by wrench.</p> 
<p>G Thread Plug</p> <p>Model <b>JZG</b> → P.737</p> 	35MPa or less	<p>Air bleeding in the circuit is possible by loosening G thread plug.</p> 

- High-Power Series
- Pneumatic Series
- Hydraulic Series**
- Valve / Coupler Hydraulic Unit
- Manual Operation Accessories
- Cautions / Others

Hole Clamp

- SFA
- SFC

Swing Clamp

- LHA
- LHC
- LHS
- LHW
- LT/LG
- TLA-2
- TLB-2
- TLA-1

Link Clamp

- LKA
- LKC
- LKW
- LM/LJ
- TMA-2
- TMA-1

Work Support

- LD
- LC
- TNC
- TC

Air Sensing Lift Cylinder

- LLW

Compact Cylinder

- LL
- LLR
- LLU
- DP
- DR
- DS
- DT

Block Cylinder

- DBA
- DBC

**Control Valve**

- BZL**
- BZT**
- BZX/JZG**

Pallet Clamp

- VS
- VT

Expansion Locating Pin

- VL
- VM
- VJ
- VK

Pull Stud Clamp

- FP
- FQ

Customized Spring Cylinder

- DWA/DWB

Model No. Indication (Speed Control Valve for Low Pressure)

**BZL 0** **10** **0** - **B**

1      2      3



**1** G Thread Size

- 10 : Thread Part G1/8A Thread
- 20 : Thread Part G1/4A Thread
- 30 : Thread Part G3/8A Thread

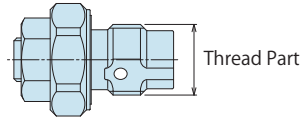

**2** Design No.

- 0 : Revision Number

**3** Control Method

- A : Meter-in
- B : Meter-out

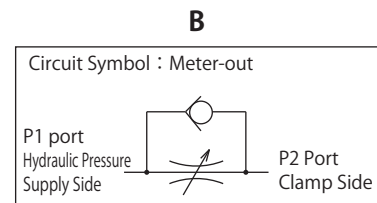
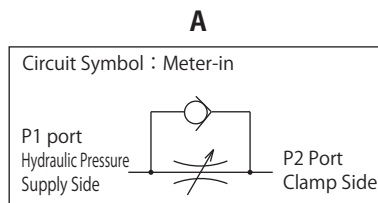

Specifications

Model No.	BZL0100-A	BZL0200-A	BZL0300-A	BZL0100-B	BZL0200-B	BZL0300-B
Max. Operating Pressure MPa	7					
Withstanding Pressure MPa	10.5					
Control Method	Meter-in			Meter-out		
G Thread Size	G1/8A	G1/4A	G3/8A	G1/8A	G1/4A	G3/8A
Cracking Pressure MPa	0.04			0.12		
Max. Passage Area mm <sup>2</sup>	2.6	5.0	11.6	2.6	5.0	10.2
Usable Fluid	General Hydraulic Oil Equivalent to ISO-VG-32					
Operating Temperature °C	0 ~ 70					
Tightening Torque for Main Body N·m	10	25	35	10	25	35

- Notes
1. Minimum passage area when fully opened is the same as the maximum passage area in the table above.
  2. It must be mounted with recommended torque. Because of the structure of the metal seal, if mounting torque is insufficient, the flow control valve may not be able to adjust the flow rate.
  3. Don't use used BZL to other clamps.  
Flow control will not be made because the bottom depth difference of G thread makes metal seal insufficient.

## Applicable Products

Model No.	DBA (Single Action) Block Cylinder	DBC (Single Action) Block Cylinder	LC (Single Action) Work Support	LHA (Double Action) Swing Clamp	LHC (Double Action) Swing Clamp	LHE (Double Action) High-Power Swing Clamp	LHS (Double Action) Swing Clamp	LHW (Double Action) Swing Clamp
BZL0100-A	(DBA0250-C□) (DBA0320-C□)	(DBC0250-C□) (DBC0320-C□)	LC0402-C□□□ LC0482-C□□□ LC0552-C□□□ LC0652-C□□□	(LHA0360-C□□□) (LHA0400-C□□□) (LHA0480-C□□□) (LHA0550-C□□□)	(LHC0360-C□□□) (LHC0400-C□□□) (LHC0480-C□□□) (LHC0550-C□□□)	/	(LHS0360-C□□□) (LHS0400-C□□□) (LHS0480-C□□□) (LHS0550-C□□□)	(LHW0400-C□□□) (LHW0480-C□□□) (LHW0550-C□□□)
BZL0100-B	DBA0250-C□ DBA0320-C□	DBC0250-C□ DBC0320-C□	/	LHA0360-C□□□ LHA0400-C□□□ LHA0480-C□□□ LHA0550-C□□□	LHC0360-C□□□ LHC0400-C□□□ LHC0480-C□□□ LHC0550-C□□□	LHE0300-C□ LHE0360-C□ LHE0400-C□ LHE0480-C□ LHE0550-C□	LHS0360-C□□□ LHS0400-C□□□ LHS0480-C□□□ LHS0550-C□□□	LHW0400-C□□□ LHW0480-C□□□ LHW0550-C□□□
BZL0200-A	(DBA0400-C□) (DBA0500-C□)	(DBC0400-C□) (DBC0500-C□)	LC0752-C□□□ LC0902-C□□□	(LHA0650-C□□□) (LHA0750-C□□□)	(LHC0650-C□□□)	/	(LHS0650-C□□□) (LHS0750-C□□□)	(LHW0650-C□□□)
BZL0200-B	DBA0400-C□ DBA0500-C□	DBC0400-C□ DBC0500-C□	/	LHA0650-C□□□ LHA0750-C□□□	LHC0650-C□□□	/	LHS0650-C□□□ LHS0750-C□□□	LHW0650-C□□□
BZL0300-A	/	/	/	(LHA0900-C□□□) (LHA1050-C□□□)	/	/	(LHS0900-C□□□) (LHS1050-C□□□)	/
BZL0300-B	/	/	/	LHA0900-C□□□ LHA1050-C□□□	/	/	LHS0900-C□□□ LHS1050-C□□□	/

Model No.	LT/LG (Single Action) Swing Clamp	LKA (Double Action) Link Clamp	LKC (Double Action) Link Clamp	LKE (Double Action) High-Power Link Clamp	LKW (Double Action) Link Clamp	LM/LJ (Single Action) Link Clamp	LL (Double Action) Linear Cylinder	LLR (Double Action) Linear Cylinder
BZL0100-A	LT0360-C□ LT0400-C□ LT0480-C□ LT0550-C□	(LKA0360-C□□□) (LKA0400-C□□□) (LKA0480-C□□□) (LKA0550-C□□□)	(LKC0400-C□□□) (LKC0480-C□□□) (LKC0550-C□□□)	LKE0300-C□ LKE0360-C□ LKE0400-C□ LKE0480-C□ LKE0550-C□	(LKW0400-C□□□) (LKW0480-C□□□) (LKW0550-C□□□)	LM0360-C□ LM0400-C□ LM0480-C□ LM0550-C□	(LL0360-C□□□) (LL0400-C□□□) (LL0480-C□□□) (LL0550-C□□□)	(LLR0360-C□□□□) (LLR0400-C□□□□) (LLR0480-C□□□□) (LLR0550-C□□□□)
BZL0100-B	/	LKA0360-C□□□ LKA0400-C□□□ LKA0480-C□□□ LKA0550-C□□□	LKC0400-C□□□ LKC0480-C□□□ LKC0550-C□□□	/	LKW0400-C□□□ LKW0480-C□□□ LKW0550-C□□□	/	LL0360-C□□□ LL0400-C□□□ LL0480-C□□□ LL0550-C□□□	LLR0360-C□□□□ LLR0400-C□□□□ LLR0480-C□□□□ LLR0550-C□□□□
BZL0200-A	LT0650-C□ LT0750-C□	(LKA0650-C□□□) (LKA0750-C□□□)	(LKC0650-C□□□)	/	(LKW0650-C□□□)	LM0650-C□ LM0750-C□	(LL0650-C□□□) (LL0750-C□□□)	(LLR0650-C□□□□) (LLR0750-C□□□□)
BZL0200-B	/	LKA0650-C□□□ LKA0750-C□□□	LKC0650-C□□□	/	LKW0650-C□□□	/	LL0650-C□□□ LL0750-C□□□	LLR0650-C□□□□ LLR0750-C□□□□
BZL0300-A	LG0900-C□ LG1050-C□	(LKA0900-C□□□) (LKA1050-C□□□)	/	/	/	LJ0902-C□ LJ1052-C□	(LL0900-C□□□) (LL1050-C□□□)	(LLR0900-C□□□□) (LLR1050-C□□□□)
BZL0300-B	/	LKA0900-C□□□ LKA1050-C□□□	/	/	/	/	LL0900-C□□□ LL1050-C□□□	LLR0900-C□□□□ LLR1050-C□□□□

Model No.	LLW (Double Action) Lift Cylinder
BZL0100-A	(LLW0360-C□□□) (LLW0400-C□□□) (LLW0480-C□□□)
BZL0100-B	LLW0360-C□□□ LLW0400-C□□□ LLW0480-C□□□

- Note 1. Flow control circuit for double acting cylinder both should have meter-out circuits for the locking side and release side except model LKE/TLA/TMA.  
Meter-in controls can be adversely affected by any air in the system.

High-Power Series

Pneumatic Series

Hydraulic Series

Valve / Coupler Hydraulic Unit

Manual Operation Accessories

Cautions / Others

Hole Clamp

SFA  
SFC

Swing Clamp

LHA  
LHC  
LHS  
LHW  
LT/LG  
TLA-2  
TLB-2  
TLA-1

Link Clamp

LKA  
LKC  
LKW  
LM/LJ  
TMA-2  
TMA-1

Work Support

LD  
LC  
TNC  
TC

Air Sensing Lift Cylinder

LLW

Compact Cylinder

LL  
LLR  
LLU  
DP  
DR  
DS  
DT

Block Cylinder

DBA  
DBC

Control Valve

BZL  
BZT  
BZX/JZG

Pallet Clamp

VS  
VT

Expansion Locating Pin

VL  
VM  
VJ  
VK

Pull Stud Clamp

FP  
FQ

Customized Spring Cylinder

DWA/DWB

● Flow Rate Graph < Hydraulic Fluids ISO-VG32 (25~35°C) >

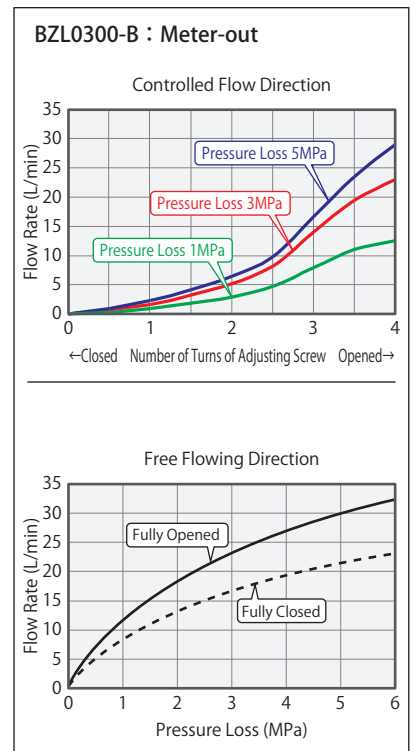
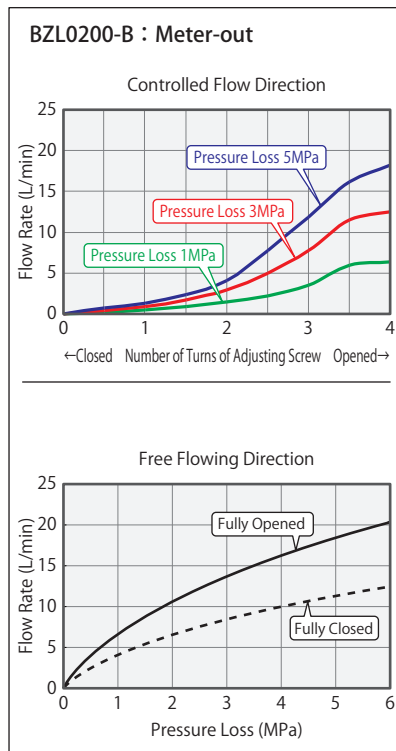
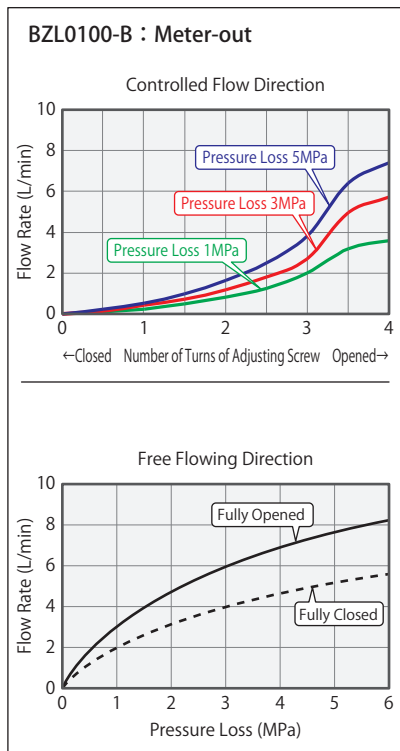
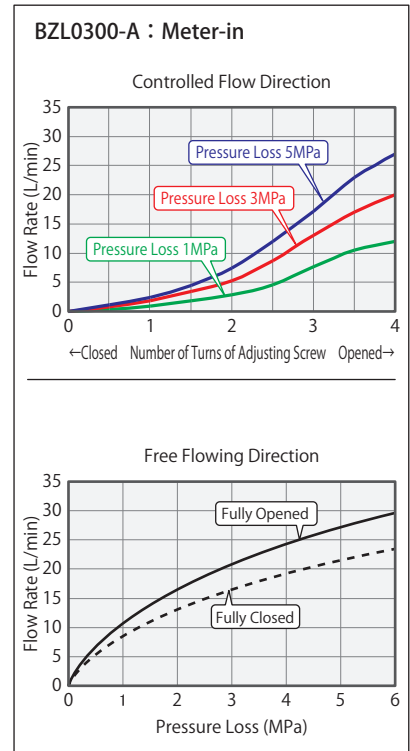
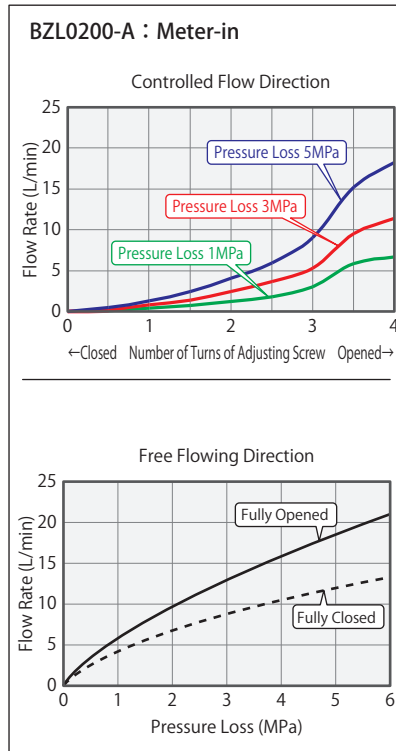
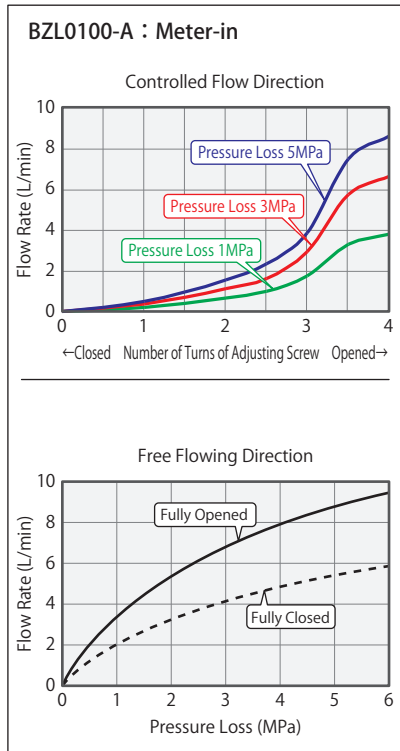

## External Dimensions

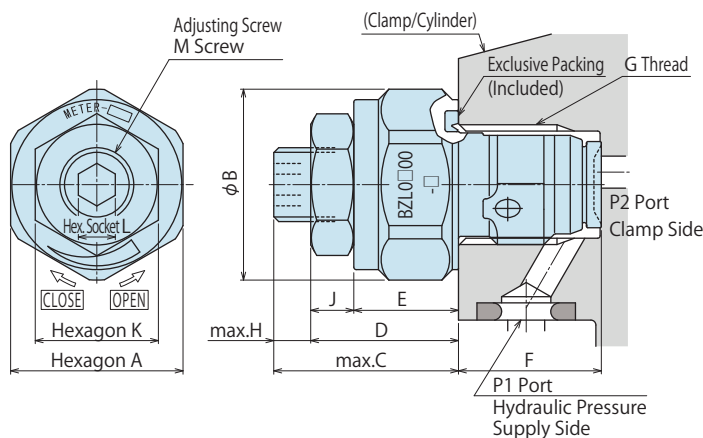

## Machining Dimensions of Mounting Area

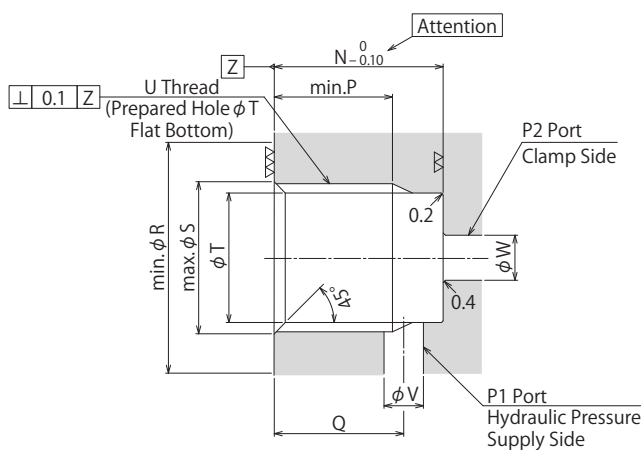

### Notes

1. Since the  $\nabla\nabla$  area is sealing part, be careful not to damage it.
2. Since the  $\nabla\nabla$  area is the metal sealing part of BZL, be careful not to damage it. (Especially when deburring)
3. No cutting chips or burr should be at the tolerance part of machining hole.
4. As shown in the drawing, P1 port is used as the hydraulic supply and P2 port as the clamp side.
5. If mounting plugs or fittings with G thread specification available in the market, the dimension '※1' should be 12.5.

## Notes

1. Please read "Notes on Hydraulic Cylinder Speed Control Circuit" to assist with proper hydraulic circuit design.  
If there is something wrong with the circuit design, it leads to the applications malfunction and damage. (Refer to P.1044)
2. It is dangerous to air bleed during operation under high pressure. It must be done under lower pressure.  
(For reference: the minimum operating range of the product within the circuit.)

(mm)

Model No.	BZL0100-□	BZL0200-□	BZL0300-□
A	14	18	22
B	15.5	20	24
C	15	16	19
D	12	13	16
E	8.5	9.5	11
F	(11.6)	(15.1)	(17.6)
G	G1/8	G1/4	G3/8
H	3	3	3
J	3.5	3.5	5
K	10	10	13
L	3	3	4
M	M6×0.75	M6×0.75	M8×0.75
N	11.5	15	17.5
P	8.5	11※1	13
Q	9	11.5	13
R (Flat Surface Area)	16	20.5	24.5
S	10	13.5	17
T	8.7	11.5	15
U	G1/8	G1/4	G3/8
V	2 ~ 3	3 ~ 4	4 ~ 5
W	2.5 ~ 5	3.5 ~ 7	4.5 ~ 9

High-Power Series

Pneumatic Series

Hydraulic Series

Valve / Coupler Hydraulic Unit

Manual Operation Accessories

Cautions / Others

Hole Clamp

SFA  
SFC

Swing Clamp

LHA  
LHC  
LHS  
LHW  
LT/LG  
TLA-2  
TLB-2  
TLA-1

Link Clamp

LKA  
LKC  
LKW  
LM/LJ  
TMA-2  
TMA-1

Work Support

LD  
LC  
TNC  
TC

Air Sensing Lift Cylinder

LLW

Compact Cylinder

LL  
LLR  
LLU  
DP  
DR  
DS  
DT

Block Cylinder

DBA  
DBC

Control Valve

BZL  
BZT  
BZX/JZG

Pallet Clamp

VS  
VT

Expansion Locating Pin

VL  
VM  
VJ  
VK

Pull Stud Clamp

FP  
FQ

Customized Spring Cylinder

DWA/DWB

## Model No. Indication (Speed Control Valve for High Pressure)

**BZT 0** **10** **0** - **A**

1
2
3



### 1 G Thread Size

- 10** : Thread Part G1/8A Thread
- 20** : Thread Part G1/4A Thread

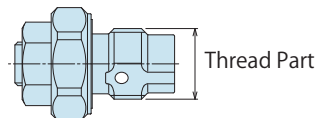

### 2 Design No.

- 0** : Revision Number

### 3 Control Method

- A** : Meter-in

※BZT doesn't have meter-out specification.

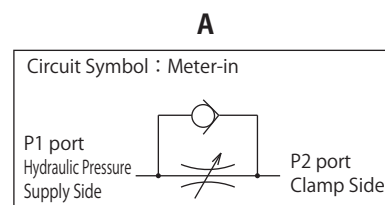

## Specifications

Model No.	BZT0100-A	BZT0200-A
Max. Operating Pressure	MPa	35
Min. Operating Pressure	MPa	10
Control Method	Meter-in	
G Thread Size	G1/8A	G1/4A
Cracking Pressure	MPa	0.04
Min. Passage Area (P2→P1:Free Flowing Direction)	mm <sup>2</sup>	3.1
Max. Passage Area	mm <sup>2</sup>	5.0
Usable Fluid	General Hydraulic Oil Equivalent to ISO-VG-32	
Operating Temperature	°C 0 ~ 70	
Tightening Torque for Main Body	N·m	25

- Notes
1. Minimum passage area when fully opened is the same as the maximum passage area in the table above.
  2. It must be mounted with recommended torque. Because of the structure of the metal seal, if mounting torque is insufficient, the flow control valve may not be able to adjust the flow rate.
  3. Don't use used BZT to other clamps.  
Flow control will not be made because the bottom depth difference of G thread makes metal seal insufficient.

## Applicable Products

Model	TLA-2 (Double Action) Swing Clamp	TLB-2 (Double Action) Swing Clamp	TLA-1 (Single Action) Swing Clamp	TMA-2 (Double Action) Link Clamp	TMA-1 (Single Action) Link Clamp
BZT0100-A	TLA0801-2C□□	TLB0801-2C□□	TLA0802-1C□	TMA0250-2C□	TMA0250-1C□
	TLA1001-2C□□	TLB1001-2C□□	TLA1002-1C□	TMA0400-2C□	TMA0400-1C□
	TLA1601-2C□□	TLB1601-2C□□	TLA1602-1C□	TMA0600-2C□	TMA0600-1C□
				TMA1000-2C□	TMA1000-1C□
BZT0200-A	TLA2001-2C□□	TLB2001-2C□□	TLA2002-1C□	TMA1600-2C□	TMA1600-1C□
	TLA2501-2C□□	TLB2501-2C□□	TLA2502-1C□	TMA2500-2C□	TMA2500-1C□
	TLA4001-2C□□	TLB4001-2C□□	TLA4002-1C□	TMA3200-2C□	TMA3200-1C□

- Notes
1. It is not recommended that using flow control valve for TL□040□, TL□060□ because it is difficult to adjust the speed.
  2. In the case of controlling TMA, TLA, both lock side and release side should be meter-in circuit.  
If meter-out circuit is used, abnormal high pressure is created, which causes oil leakage and damage.

## External Dimensions

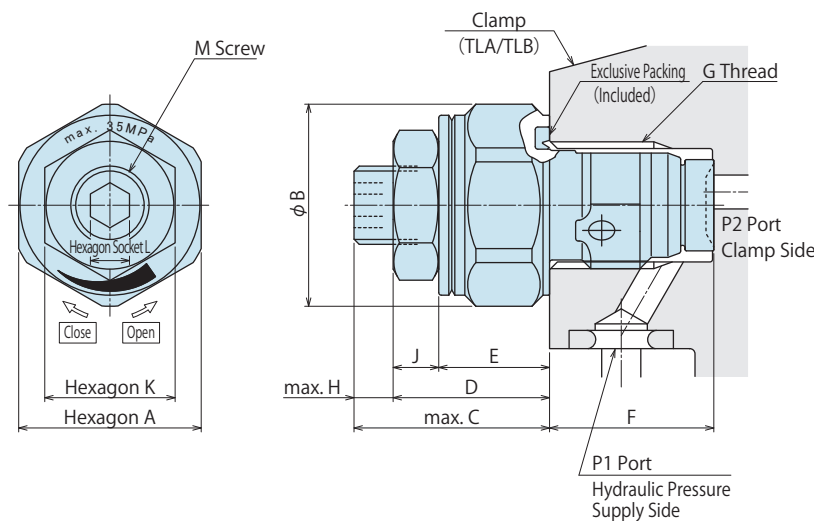

(mm)		
Model	BZT0100-A	BZT0200-A
A	14	18
B	15.5	20
C	15	16
D	12	13
E	8.5	9.5
F	(12.6)	(16.1)
G	G1/8	G1/4
H	3	3
J	3.5	3.5
K	10	10
L	3	3
M	M6×0.75	M6×0.75

### Notes

- Please mount it directly to the clamps made by KOSMEK (Model : TLA,TLB,TMA).  
(This cannot be used for other actuators such as our low pressure series.)
- Contact us if it is used in the hydraulic circuit for a different purpose.

## Notes

- Please read "Notes on Hydraulic Cylinder Speed Control Circuit" to assist with proper hydraulic circuit design.  
If there is something wrong with the circuit design, it leads to the applications malfunction and damage. (Refer to P.1044)
- It is dangerous to air bleed during operation under high pressure. It must be done under lower pressure.  
(For reference: the minimum operating range of the product within the circuit.)
- When the cylinder capacity is small, it is highly possible that the speed of flow cannot be controlled properly.  
(Recommended cylinder capacity : 3cm<sup>3</sup> or more)

High-Power  
Series

Pneumatic Series

**Hydraulic Series**
Valve / Coupler  
Hydraulic UnitManual Operation  
Accessories

Cautions / Others

Hole Clamp

SFA  
SFC

Swing Clamp

LHA  
LHC  
LHS  
LHW  
LT/LG  
TLA-2  
TLB-2  
TLA-1

Link Clamp

LKA  
LKC  
LKW  
LM/LJ  
TMA-2  
TMA-1

Work Support

LD  
LC  
TNC  
TCAir Sensing  
Lift Cylinder

LLW

Compact Cylinder

LL  
LLR  
LLU  
DP  
DR  
DS  
DT

Block Cylinder

DBA  
DBC
**Control Valve**
BZL  
**BZT**  
BZX/JZG

Pallet Clamp

VS  
VTExpansion  
Locating PinVL  
VM  
VJ  
VK

Pull Stud Clamp

FP  
FQCustomized  
Spring Cylinder

DWA/DWB



## Model No. Indication (Air Bleed Valve)

**BZX0 1 0**

1 2



### 1 G Thread Size

- 1 : Thread Part G1/8A Thread
- 2 : Thread Part G1/4A Thread
- 3 : Thread Part G3/8A Thread

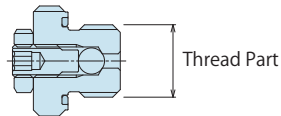

### 2 Design No.

- 0 : Revision Number

## Specifications

Model No.	BZX010	BZX020	BZX030
Max. Operating Pressure MPa	25		
Withstanding Pressure MPa	37.5		
G Thread Size	G1/8A	G1/4A	G3/8A
Usable Fluid	General Hydraulic Oil Equivalent to ISO-VG-32		
Operating Temperature °C	0 ~ 70		
Tightening Torque for Main Body N·m	10	25	35

## Circuit Symbol

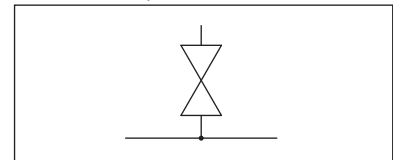

- Notes
- Do not over loosen the plug during air venting.  
(Do not loosen for more than 2 turns from the fully closed position.)
  - It is dangerous to have air venting operation under high pressure. It must be done under lower pressure.  
(For reference: the minimum operation pressure range of the product within the circuit)
  - Refer to the processing dimensions for BZL mounting area.

## Applicable Products

Model No.	DBA (Single Action) Block Cylinder	DBC (Single Action) Block Cylinder	LC (Single Action) Work Support	LHA (Double Action) Swing Clamp	LHC (Double Action) Swing Clamp	LHE (Double Action) High-Power Swing Clamp	LHS (Double Action) Swing Clamp	LHW (Double Action) Swing Clamp
BZX010	DBA0250-C□ DBA0320-C□	DBC0250-C□ DBC0320-C□	LC0402-C□□□ LC0482-C□□□ LC0552-C□□□ LC0652-C□□□	LHA0360-C□□□ LHA0400-C□□□ LHA0480-C□□□ LHA0550-C□□□	LHC0360-C□□□ LHC0400-C□□□ LHC0480-C□□□ LHC0550-C□□□	LHE0300-C□ LHE0360-C□ LHE0400-C□ LHE0480-C□ LHE0550-C□	LHS0360-C□□□ LHS0400-C□□□ LHS0480-C□□□ LHS0550-C□□□	LHW0400-C□□□ LHW0480-C□□□ LHW0550-C□□□
BZX020	DBA0400-C□ DBA0500-C□	DBC0400-C□ DBC0500-C□	LC0752-C□□□ LC0902-C□□□	LHA0650-C□□□ LHA0750-C□□□	LHC0650-C□□□		LHS0650-C□□□ LHS0750-C□□□	LHW0650-C□□□
BZX030				LHA0900-C□□□ LHA1050-C□□□			LHS0900-C□□□ LHS1050-C□□□	

Model No.	LT/LG (Single Action) Swing Clamp	LKA (Double Action) Link Clamp	LKC (Double Action) Link Clamp	LKE (Double Action) High-Power Link Clamp	LKW (Double Action) Link Clamp	LM/LJ (Single Action) Link Clamp	LL (Double Action) Linear Cylinder	LLR (Double Action) Linear Cylinder
BZX010	LT0360-C□ LT0400-C□ LT0480-C□ LT0550-C□	LKA0360-C□□□ LKA0400-C□□□ LKA0480-C□□□ LKA0550-C□□□	LKC0400-C□□□ LKC0480-C□□□ LKC0550-C□□□	LKE0300-C□ LKE0360-C□ LKE0400-C□ LKE0480-C□ LKE0550-C□	LKW0400-C□□□ LKW0480-C□□□ LKW0550-C□□□	LM0360-C□ LM0400-C□ LM0480-C□ LM0550-C□	LL0360-C□□□ LL0400-C□□□ LL0480-C□□□ LL0550-C□□□	LLR0360-C□□□□ LLR0400-C□□□□ LLR0480-C□□□□ LLR0550-C□□□□
BZX020	LT0650-C□ LT0750-C□	LKA0650-C□□□ LKA0750-C□□□	LKC0650-C□□□		LKW0650-C□□□	LM0650-C□ LM0750-C□	LL0650-C□□□ LL0750-C□□□	LLR0650-C□□□□ LLR0750-C□□□□
BZX030	LG0900-C□ LG1050-C□	LKA0900-C□□□ LKA1050-C□□□				LJ0902-C□ LJ1052-C□	LL0900-C□□□ LL1050-C□□□	LLR0900-C□□□□ LLR1050-C□□□□

Model No.	LLW (Double Action) Lift Cylinder
BZX010	LLW0360-C□□□ LLW0400-C□□□ LLW0480-C□□□

## External Dimensions

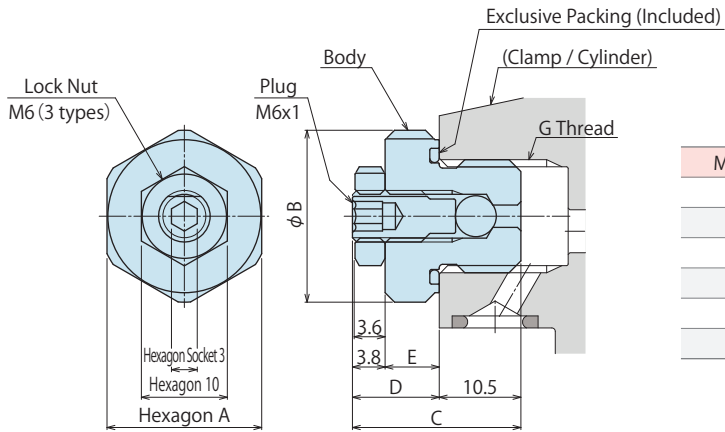

Model No.	BZX010	BZX020	BZX030
A	14	18	22
B	15.5	20	24
C	19.8	20.6	20.6
D	9.3	10.1	10.1
E	5.5	6.3	6.3
G	G1/8	G1/4	G3/8

(mm)

High-Power  
Series

Pneumatic Series

Hydraulic Series

Valve / Coupler  
Hydraulic UnitManual Operation  
Accessories

Cautions / Others

Hole Clamp

SFA  
SFC

Swing Clamp

LHA  
LHC  
LHS  
LHW  
LT/LG  
TLA-2  
TLB-2  
TLA-1

Link Clamp

LKA  
LKC  
LKW  
LM/LJ  
TMA-2  
TMA-1

Work Support

LD  
LC  
TNC  
TCAir Sensing  
Lift Cylinder

LLW

Compact Cylinder

LL  
LLR  
LLU  
DP  
DR  
DS  
DT

Block Cylinder

DBA  
DBC

Control Valve

BZL  
BZT

BZX/JZG

Pallet Clamp

VS  
VTExpansion  
Locating PinVL  
VM  
VJ  
VK

Pull Stud Clamp

FP  
FQCustomized  
Spring Cylinder

DWA/DWB

## Model No. Indication (G Thread Plug with Air Bleeding Function)

**JZG0 1 0**

1 2



### 1 G Thread Size

- 1 : Thread Part G1/8A Thread
- 2 : Thread Part G1/4A Thread
- 3 : Thread Part G3/8A Thread

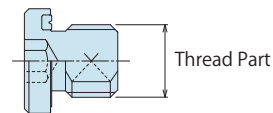

### 2 Design No.

- 0 : Revision Number

## Specifications

Model No.	JZG010	JZG020	JZG030
Max. Operating Pressure MPa	35		
Withstanding Pressure MPa	42		
G Thread Size	G1/8A	G1/4A	G3/8A
Usable Fluid	General Hydraulic Oil Equivalent to ISO-VG-32		
Operating Temperature °C	0 ~ 70		
Tightening Torque for Main Body N·m	10	25	35

- Notes
- It is dangerous to have air venting operation under high pressure. It must be done under lower pressure.  
(For reference: the minimum operation pressure range of the product within the circuit)
  - Refer to the processing dimensions for BZL mounting area.

## Applicable Products

Model No.	DBA (Single Action) Block Cylinder	DBC (Single Action) Block Cylinder	LC (Single Action) Work Support	LHA (Double Action) Swing Clamp	LHC (Double Action) Swing Clamp	LHE (Double Action) High-Power Swing Clamp	LHS (Double Action) Swing Clamp	LHW (Double Action) Swing Clamp
JZG010	DBA0250-C□ DBA0320-C□	DBC0250-C□ DBC0320-C□	LC0402-C□□□ LC0482-C□□□ LC0552-C□□□ LC0652-C□□□	LHA0360-C□□□ LHA0400-C□□□ LHA0480-C□□□ LHA0550-C□□□	LHC0360-C□□□ LHC0400-C□□□ LHC0480-C□□□ LHC0550-C□□□	LHE0300-C□ LHE0360-C□ LHE0400-C□ LHE0480-C□ LHE0550-C□	LHS0360-C□□□ LHS0400-C□□□ LHS0480-C□□□ LHS0550-C□□□	LHW0400-C□□□ LHW0480-C□□□ LHW0550-C□□□
JZG020	DBA0400-C□ DBA0500-C□	DBC0400-C□ DBC0500-C□	LC0752-C□□□ LC0902-C□□□	LHA0650-C□□□ LHA0750-C□□□	LHC0650-C□□□		LHS0650-C□□□ LHS0750-C□□□	LHW0650-C□□□
JZG030				LHA0900-C□□□ LHA1050-C□□□			LHS0900-C□□□ LHS1050-C□□□	

Model No.	LT/LG (Single Action) Swing Clamp	LKA (Double Action) Link Clamp	LKC (Double Action) Link Clamp	LKE (Double Action) High-Power Link Clamp	LKW (Double Action) Link Clamp	LM/LJ (Single Action) Link Clamp	LL (Double Action) Linear Cylinder	LLR (Double Action) Linear Cylinder
JZG010	LT0360-C□ LT0400-C□ LT0480-C□ LT0550-C□	LKA0360-C□□□ LKA0400-C□□□ LKA0480-C□□□ LKA0550-C□□□	LKC0400-C□□□ LKC0480-C□□□ LKC0550-C□□□	LKE0300-C□ LKE0360-C□ LKE0400-C□ LKE0480-C□ LKE0550-C□	LKW0400-C□□□ LKW0480-C□□□ LKW0550-C□□□	LM0360-C□ LM0400-C□ LM0480-C□ LM0550-C□	LL0360-C□□□ LL0400-C□□□ LL0480-C□□□ LL0550-C□□□	LLR0360-C□□□□□ LLR0400-C□□□□□ LLR0480-C□□□□□ LLR0550-C□□□□□
JZG020	LT0650-C□ LT0750-C□	LKA0650-C□□□ LKA0750-C□□□	LKC0650-C□□□		LKW0650-C□□□	LM0650-C□ LM0750-C□	LL0650-C□□□ LL0750-C□□□	LLR0650-C□□□□□ LLR0750-C□□□□□
JZG030	LG0900-C□ LG1050-C□	LKA0900-C□□□ LKA1050-C□□□				LJ0902-C□ LJ1052-C□	LL0900-C□□□ LL1050-C□□□	LLR0900-C□□□□□ LLR1050-C□□□□□

Model No.	LLW (Double Action) Lift Cylinder	TLA-2 (Double Action) Swing Clamp	TLB-2 (Double Action) Swing Clamp	TLA-1 (Single Action) Swing Clamp	TMA-2 (Double Action) Link Clamp	TMA-1 (Single Action) Link Clamp
JZG010	LLW0360-C□□□□□ LLW0400-C□□□□□ LLW0480-C□□□□□	TLA0401-2C□□□ TLA0601-2C□□□ TLA0801-2C□□□ TLA1001-2C□□□ TLA1601-2C□□□	TLB0401-2C□□□ TLB0601-2C□□□ TLB0801-2C□□□ TLB1001-2C□□□ TLB1601-2C□□□	TLA0402-1C□ TLA0602-1C□ TLA0802-1C□ TLA1002-1C□ TLA1602-1C□	TMA0250-2C□ TMA0400-2C□ TMA0600-2C□ TMA1000-2C□	TMA0250-1C□ TMA0400-1C□ TMA0600-1C□ TMA1000-1C□
JZG020		TLA2001-2C□□□ TLA2501-2C□□□ TLA4001-2C□□□	TLB2001-2C□□□ TLB2501-2C□□□ TLB4001-2C□□□	TLA2002-1C□ TLA2502-1C□ TLA4002-1C□	TMA1600-2C□ TMA2500-2C□ TMA3200-2C□	TMA1600-1C□ TMA2500-1C□ TMA3200-1C□

## External Dimensions

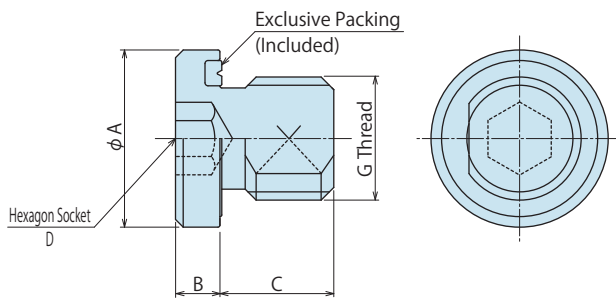

Model No.	JZG010	JZG020	JZG030
A	14	18	22
B	3.5	4.5	4.5
C	8	9	10
D	5	6	8
G	G1/8A	G1/4A	G3/8A

(mm)

High-Power  
Series

Pneumatic Series

Hydraulic Series

Valve / Coupler  
Hydraulic UnitManual Operation  
Accessories

Cautions / Others

Hole Clamp

SFA  
SFC

Swing Clamp

LHA  
LHC  
LHS  
LHW  
LT/LG  
TLA-2  
TLB-2  
TLA-1

Link Clamp

LKA  
LKC  
LKW  
LM/LJ  
TMA-2  
TMA-1

Work Support

LD  
LC  
TNC  
TCAir Sensing  
Lift Cylinder

LLW

Compact Cylinder

LL  
LLR  
LLU  
DP  
DR  
DS  
DT

Block Cylinder

DBA  
DBC

Control Valve

BZL  
BZT

BZX/JZG

Pallet Clamp

VS  
VTExpansion  
Locating PinVL  
VM  
VJ  
VK

Pull Stud Clamp

FP  
FQCustomized  
Spring Cylinder

DWA/DWB

## ● Cautions

### ● Installation Notes (For Hydraulic Series)

- 1) Check the Usable Fluid
  - Please use the appropriate fluid by referring to the Hydraulic Fluid List.
- 2) Procedure before Piping
  - The pipeline, piping connector and fixture circuits should be cleaned by thorough flushing.
  - The dust and cutting chips in the circuit may lead to fluid leakage and malfunction.
  - There is no filter provided with Kosmek' s product except for a part of valves which prevents foreign materials and contaminants from getting into the circuit.
- 3) Applying Sealing Tape
  - Wrap with tape 1 to 2 times following the screw direction.
  - Pieces of the sealing tape can lead to oil leakage and malfunction.
  - In order to prevent a foreign substance from going into the product during the piping work, it should be carefully cleaned before working.
- 4) Air Bleeding of the Hydraulic Circuit
  - If the hydraulic circuit has excessive air, the action time may become very long. If air enters the circuit after connecting the hydraulic port or under the condition of no air in the oil tank, please perform the following steps.
    - ① Reduce hydraulic pressure to less than 2MPa.
    - ② Loosen the cap nut of pipe fitting closest to the clamp by one full turn.
    - ③ Wiggle the pipeline to loosen the outlet of pipe fitting.  
Hydraulic fluid mixed with air comes out.

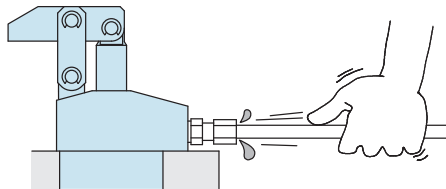

- ④ Tighten the cap nut after bleeding.
- ⑤ It is more effective to bleed air at the highest point inside the circuit or at the end of the circuit.  
(Set an air bleeding valve at the highest point inside the circuit.)

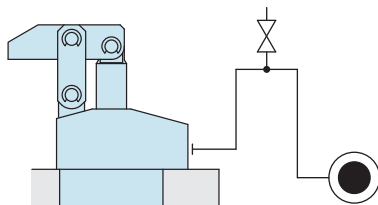

### 5) Checking Looseness and Retightening

- At the beginning of the machine installation, the bolt and nut may be tightened lightly. Check the looseness and re-tighten as required.

### ● Hydraulic Fluid List

Maker	ISO Viscosity Grade ISO-VG-32	
	Anti-Wear Hydraulic Oil	Multi-Purpose Hydraulic Oil
Showa Shell Sekiyu	Tellus S2 M 32	Morlina S2 B 32
Idemitsu Kosan	Daphne Hydraulic Fluid 32	Daphne Super Multi Oil 32
JX Nippon Oil & Energy	Super Hyrando 32	Super Mulpus DX 32
Cosmo Oil	Cosmo Hydro AW32	Cosmo New Mighty Super 32
ExxonMobil	Mobil DTE 24	Mobil DTE 24 Light
Matsumura Oil	Hydol AW-32	
Castrol	Hyspin AWS 32	

Note As it may be difficult to purchase the products as shown in the table from overseas, please contact the respective manufacturer.

- High-Power Series
- Pneumatic Series
- Hydraulic Series
- Valve / Coupler Hydraulic Unit
- Manual Operation Accessories
- Cautions / Others

**Cautions**

- Installation Notes (For Hydraulic Series)
- Hydraulic Fluid List
- Notes on Hydraulic Cylinder Speed Control Circuit
- Notes on Handling
- Maintenance/Inspection
- Warranty

**Company Profile**

- Company Profile
- Our Products
- History

**Index**

- Search by Alphabetical Order

**Sales Offices**

● Notes on Hydraulic Cylinder Speed Control Unit



Please pay attention to the cautions below. Design the hydraulic circuit for controlling the action speed of hydraulic cylinder. Improper circuit design may lead to malfunctions and damages. Please review the circuit design in advance.

● Flow Control Circuit for Single Acting Cylinder

For spring return single acting cylinders, restricting flow during release can extremely slow down or disrupt release action. The preferred method is to control the flow during the lock action using a valve that has free-flow in the release direction. It is also preferred to provide a flow control valve at each actuator.

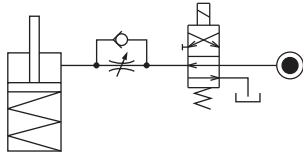

Accelerated clamping speed by excessive hydraulic flow to the cylinder may sustain damage. In this case add flow control to regulate flow. (Please add flow control to release flow if the lever weight is put on at the time of release action when using swing clamps.)

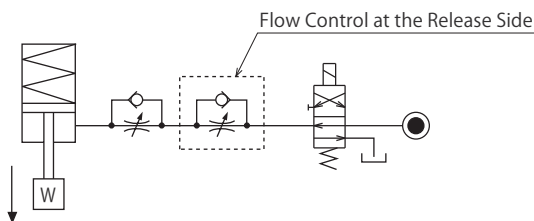

● Flow Control Circuit for Double Acting Cylinder

Flow control circuit for double acting cylinder should have meter-out circuits for both the lock and release sides. Meter-in control can have adverse effect by presence of air in the system.

However, in the case of controlling LKE, TMA, TLA, both lock side and release side should be meter-in circuit.

Refer to P.47 for speed adjustment of LKE.

For TMA and TLA, if meter-out circuit is used, abnormal high pressure is created, which causes oil leakage and damage.

【Meter-out Circuit】 (Except LKE/TMA/TLA)

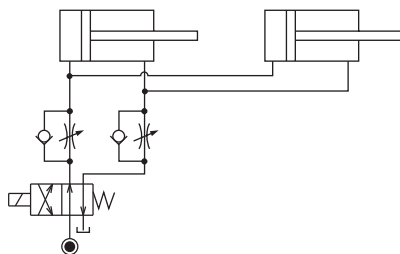

【Meter-in Circuit】 (LKE/TMA/TLA must be controlled with meter-in.)

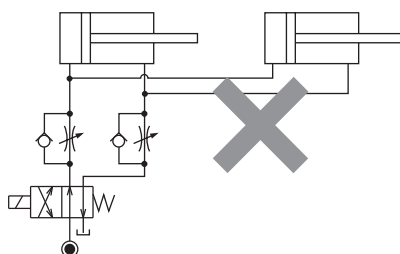

In the case of meter-out circuit, the hydraulic circuit should be designed with the following points.

- ① Single acting components should not be used in the same flow control circuit as the double acting components. The release action of the single acting cylinders may become erratic or very slow.

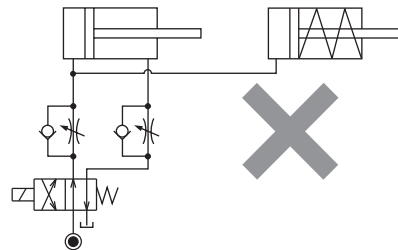

Refer to the following circuit when both the single acting cylinder and double acting cylinder are used together.

- Separate the control circuit.

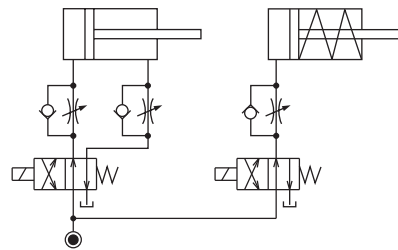

- Reduce the influence of double acting cylinder control unit. However, due to the back pressure in tank line, single action cylinder is activated after double action cylinder works.

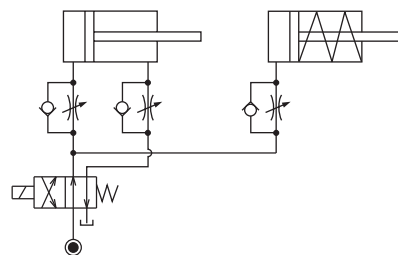

- ② In the case of meter-out circuit, the inner circuit pressure may increase during the cylinder action because of the fluid supply. The increase of the inner circuit pressure can be prevented by reducing the supplied fluid beforehand via the flow control valve. Especially when using sequence valve or pressure switches for clamping detection. If the back pressure is more than the set pressure then the system will not work as it is designed to.

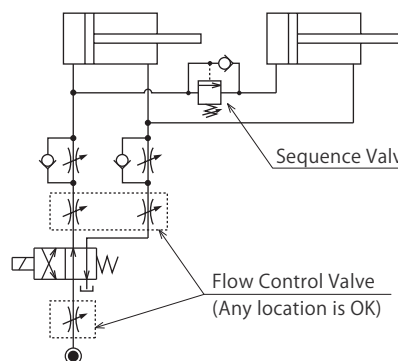

## ● Cautions

### ● Notes on Handling

- 1) It should be handled by qualified personnel.
  - The hydraulic machine and air compressor should be handled and maintained by qualified personnel.
- 2) Do not handle or remove the machine unless the safety protocols are ensured.
  - ① The machine and equipment can only be inspected or prepared when it is confirmed that the preventive devices are in place.
  - ② Before the machine is removed, make sure that the above-mentioned safety measures are in place. Shut off the air of hydraulic source and make sure no pressure exists in the hydraulic and air circuit.
  - ③ After stopping the machine, do not remove until the temperature cools down.
  - ④ Make sure there is no abnormality in the bolts and respective parts before restarting the machine or equipment.
- 3) Do not touch clamps (cylinder) while clamps (cylinder) is working. Otherwise, your hands may be injured due to clinching.

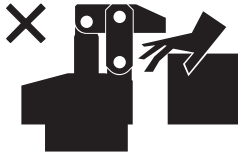

- 4) Do not disassemble or modify.
  - If the equipment is taken apart or modified, the warranty will be voided even within the warranty period.

### ● Maintenance and Inspection

- 1) Removal of the Machine and Shut-off of Pressure Source
  - Before the machine is removed, make sure that the above-mentioned safety measures are in place. Shut off the air of hydraulic source and make sure no pressure exists in the hydraulic and air circuit.
  - Make sure there is no abnormality in the bolts and respective parts before restarting.
- 2) Regularly clean the area around the piston rod and plunger.
  - If it is used when the surface is contaminated with dirt, it may lead to packing seal damage, malfunctioning, fluid leakage and air leaks.

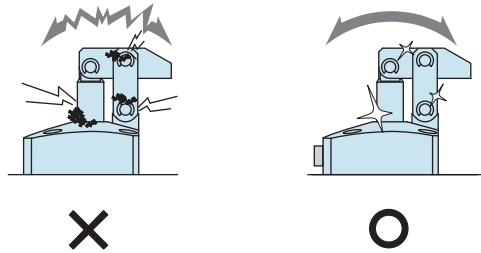

- 3) Please clean out the reference surface regularly (taper reference surface and seating surface) of locating machine. (VS/VT/VL/VM/VJ/VK/WVS/WM/WK/VX/VXF)
  - Location products, except VX/VXF model, can remove contaminants with cleaning functions. When installing pallets make sure there is no thick sludge like substances on pallets.
  - Continuous use with dirt on components will lead to locating functions not work properly, leaking and malfunction.

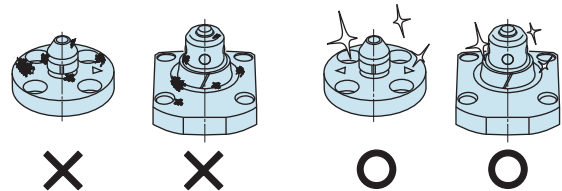

- 4) If disconnecting by couplers on a regular basis, air bleeding should be carried out daily to avoid air mixed in the circuit.
- 5) Regularly tighten nuts, bolts, pins, cylinders and pipe line to ensure proper use.
- 6) Make sure the hydraulic fluid has not deteriorated.
- 7) Make sure there is smooth action and no abnormal noise.
  - Especially when it is restarted after left unused for a long period, make sure it can be operated correctly.
- 8) The products should be stored in the cool and dark place without direct sunshine or moisture.
- 9) Please contact us for overhaul and repair.

## Cautions

[Installation Notes  
\(For Hydraulic Series\)](#)
[Hydraulic Fluid List](#)
[Notes on Hydraulic Cylinder  
Speed Control Circuit](#)
[Notes on Handling](#)
[Maintenance/  
Inspection](#)
[Warranty](#)

## Company Profile

[Company Profile](#)
[Our Products](#)
[History](#)

## Index

[Search by  
Alphabetical Order](#)

## Sales Offices

## ● Warranty

### 1) Warranty Period

- The product warranty period is 18 months from shipment from our factory or 12 months from initial use, whichever is earlier.

### 2) Warranty Scope

- If the product is damaged or malfunctions during the warranty period due to faulty design, materials or workmanship, we will replace or repair the defective part at our expense.

Defects or failures caused by the following are not covered.

- ① If the stipulated maintenance and inspection are not carried out.
- ② If the product is used while it is not suitable for use based on the operator's judgment, resulting in defect.
- ③ If it is used or handled in inappropriate way by the operator.  
(Including damage caused by the misconduct of the third party.)
- ④ If the defect is caused by reasons other than our responsibility.
- ⑤ If repair or modifications are carried out by anyone other than Kosmek, or without our approval and confirmation, it will void warranty.
- ⑥ Other caused by natural disasters or calamities not attributable to our company.
- ⑦ Parts or replacement expenses due to parts consumption and deterioration.  
(Such as rubber, plastic, seal material and some electric components.)

Damages excluding from direct result of a product defect shall be excluded from the warranty.



# Sales Offices

## Sales Offices across the World

Japan	<b>TEL. +81-78-991-5162</b>	<b>FAX. +81-78-991-8787</b>
Overseas Sales	KOSMEK LTD. 1-5, 2-chome, Murotani, Nishi-ku, Kobe-city, Hyogo, Japan 651-2241 〒651-2241 兵庫県神戸市西区室谷2丁目1番5号	
USA	<b>TEL. +1-630-241-3465</b>	<b>FAX. +1-630-241-3834</b>
KOSMEK (USA) LTD.	1441 Branding Avenue, Suite 110, Downers Grove, IL 60515 USA	
China	<b>TEL.+86-21-54253000</b>	<b>FAX.+86-21-54253709</b>
KOSMEK (CHINA) LTD. 考世美(上海)貿易有限公司	21/F, Orient International Technology Building, No.58, Xiangchen Rd, Pudong Shanghai 200122., P.R.China 中国上海市浦东新区向城路58号东方国际科技大厦21F室 200122	
Thailand	<b>TEL. +66-2-715-3450</b>	<b>FAX. +66-2-715-3453</b>
Thailand Representative Office	67 Soi 58, RAMA 9 Rd., Suanluang, Suanluang, Bangkok 10250, Thailand	
Taiwan (Taiwan Exclusive Distributor)	<b>TEL. +886-2-82261860</b>	<b>FAX. +886-2-82261890</b>
Full Life Trading Co., Ltd. 盈生貿易有限公司	16F-4, No.2, Jian Ba Rd., Zhonghe District, New Taipei City Taiwan 23511 台湾新北市中和區建八路2號 16F-4 (遠東世紀廣場)	
Philippines (Philippines Exclusive Distributor)	<b>TEL.+63-2-310-7286</b>	<b>FAX. +63-2-310-7286</b>
G.E.T. Inc, Phil.	Victoria Wave Special Economic Zone Mt. Apo Building, Brgy. 186, North Caloocan City, Metro Manila, Philippines 1427	
Europe (Europe Exclusive Distributor)	<b>TEL. +43-463-287587-10</b>	<b>FAX. +43-463-287587-20</b>
KOS-MECH GmbH	Schleppeplatz 2 9020 Klagenfurt Austria	
Indonesia (Indonesia Exclusive Distributor)	<b>TEL. +62-21-5818632</b>	<b>FAX. +62-21-5814857</b>
P.T PANDU HYDRO PNEUMATICS	Ruko Green Garden Blok Z- II No.51 Rt.005 Rw.008 Kedoya Utara-Kebon Jeruk Jakarta Barat 11520 Indonesia	

## Sales Offices in Japan

Head Office	<b>TEL.078-991-5115</b>	<b>FAX.078-991-8787</b>
Osaka Sales Office	〒651-2241 兵庫県神戸市西区室谷2丁目1番5号	
Overseas Sales		
Tokyo Sales Office	<b>TEL.048-652-8839</b>	<b>FAX.048-652-8828</b>
	〒331-0815 埼玉県さいたま市北区大成町4丁目81番地	
Nagoya Sales Office	<b>TEL.0566-74-8778</b>	<b>FAX.0566-74-8808</b>
	〒446-0076 愛知県安城市美園町2丁目10番地1	
Fukuoka Sales Office	<b>TEL.092-433-0424</b>	<b>FAX.092-433-0426</b>
	〒812-0006 福岡県福岡市博多区上牟田1丁目8-10-101	

# Global Network



Asia Detailed Map



● FOR FURTHER INFORMATION ON UNLISTED SPECIFICATIONS AND SIZES, PLEASE CALL US.  
 ● SPECIFICATIONS IN THIS CATALOG ARE SUBJECT TO CHANGE WITHOUT NOTICE.

